

Micro LC **DUST SHUTTER ADAPTER** Premium Shuttered Duplex

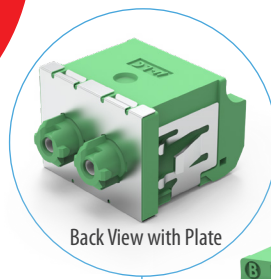

Back View with Plate

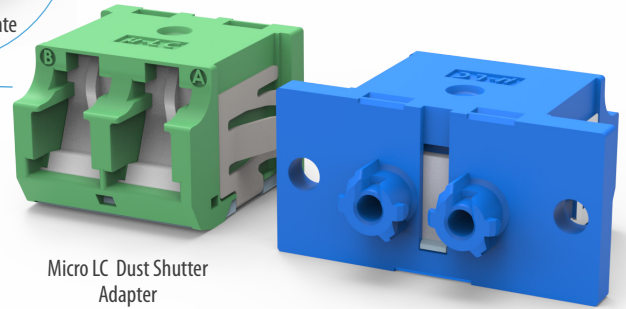

Micro LC Dust Shutter
Adapter

Micro LC Dust Shutter Adapter with Flange

SENKO's Micro LC Dust Shutter hybrid adapter delivers superior performance and reliability in a compact design. Its unique design, converting conventional LC connections to the more compact Micro LC connectors, frees up valuable space in enclosures and cabinets.

A non-ferrule contact shutter offers IP5X protection from dust while blocking potentially harmful laser radiation. Additionally, an optional shielding plate is available for applications requiring reduction in EMI interference.

All SENKO Micro LC adapters are designed either to be snapped into panel cut-outs or screwed into place using an appropriate screw and nut. Adapters using the larger mounting flange will require additional space between each cut-out.

FEATURES

- Micro LC to LC hybrid adapter
- Shutter for laser and dust protection
- EMI protection with metal plate option
- One-handed automatic shutter operation
- Traceability with visible light source
- Flanged and non-flanged options

APPLICATIONS

- Hyperscale, edge, enterprise and colocation data centers
- Onboard optics
- Test equipment
- Plug and play modules

KEY BENEFITS

- ✓ **Dust and laser protection**
- ✓ **EMI plate**
- ✓ **Space savings**

Mechanical Data

	Value
Durability	200 matings per GR-326 Core
Fixing Method	Snap-fit or screw and nut (<i>adapter with flange</i>)
Housing Material Type	Plastic
Shutter Material Type	Plastic
Sleeve Material	Zirconia
Dust Protection Method	Integrated shutter mechanism (<i>operated by connector insertion</i>)

Optical Data

	Value
Typical Insertion Loss (dB)*	0.10
Max. Insertion Loss (dB)*	0.20

* Based on master grade jumper to low loss random mating test

Environmental Data

	Value
Operating Temperature	-40°C to +75°C
RoHS Compliance	2015/863 RoHS
REACH Compliance	Yes
Free of Halogen	Yes
Humidity Resistance	95%

Adapter Drawing

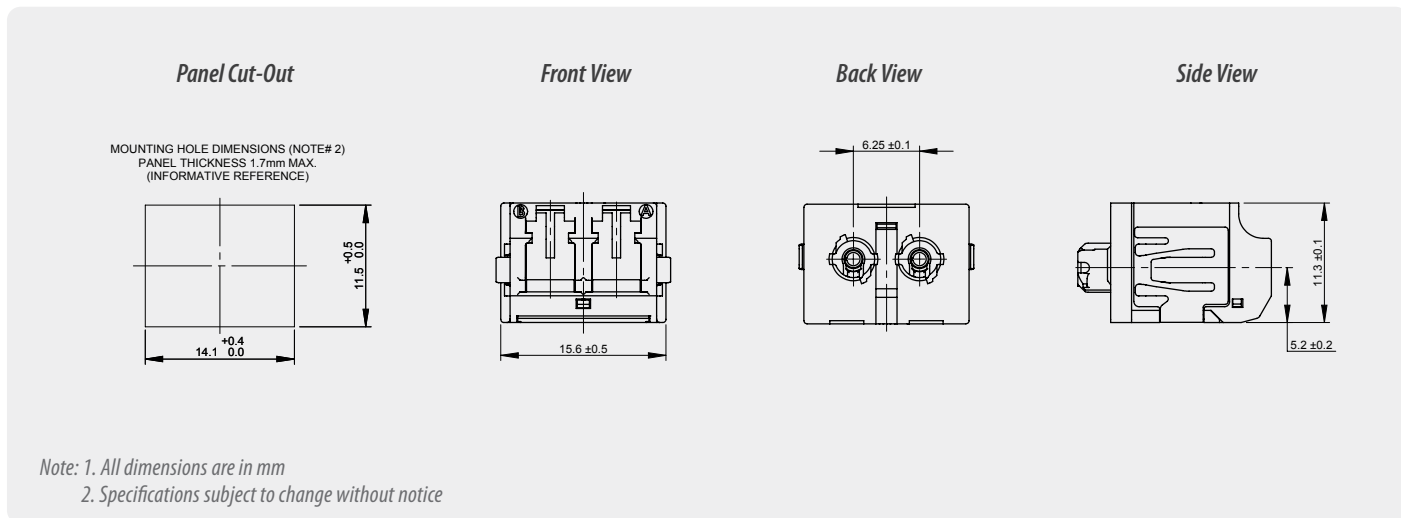

Adapter Drawing with EMI Plate

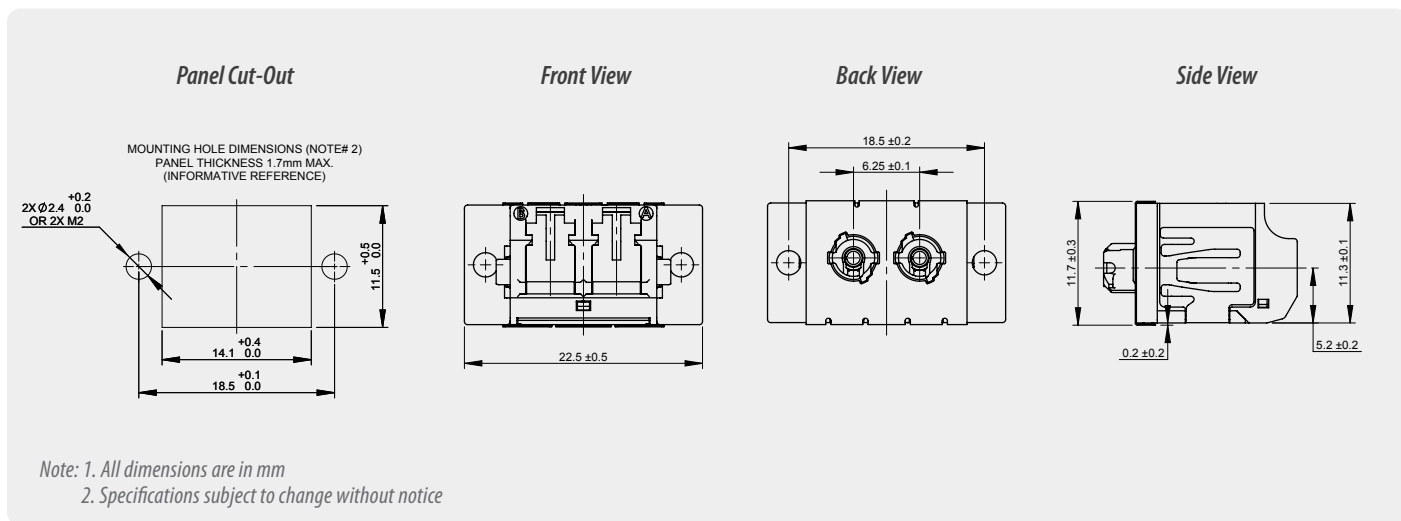

ORDERING

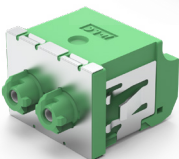

ADAPTER TYPE		HOUSING COLOR	FLANGE	SHUTTER
95B-P	µLC Premium Duplex	1 Blue (SM PC/UPC)	0 No Flange	A Shutter
95BE-P	µLC Premium Duplex with EMI Plate	3 Green (SM/APC)	1 With Flange	
		8 Beige (MM OM1)		
		9 Aqua (MM OM3)		

95B-P - 1 - 0 - A ORDER CODE example

SENKO[®]

Advanced Components

sales@senko.com
1-858-623-3300

senko.com/contact